

For Lease ~ Professional Office  
**VAN NEST OFFICE PARK**  
3836-3840 Quakerbridge Road, Hamilton, NJ

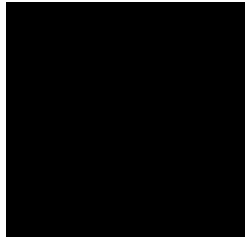

**Office/  
Medical  
Space**



- New brick construction, with perimeter windows throughout; 2-story atrium lobby with built-in waterfall
- Parking: 5/1,000 SF
- Operating expenses est. at \$7.40/SF [=taxes \$4.25 + OpEx \$3.15]
- Attractive corporate setting overlooking the Van Nest Forest Reserve
- Minutes from Hamilton Train Station (Northeast Corridor Line) & close proximity to Hospitals, Route One
- Restaurants, banking and shopping within walking distance

**Office/Medical  
Space Available Immediately**

**Building One:**

3836 Quakerbridge Road

**Suite 101 – 3,623 SF Office**

**Suite 206 – 3,711 SF Medical**

**Building Two:**

3840 Quakerbridge Road

**Suite 100 – 8,228 SF Built-Out Medical**

3 sides glass windows, available August 2021

**Rental Rate: \$17.50/SF plus  
all operating expenses, utilities and janitorial**

**Contact: Jerry Fennelly, Patrick Dintrone**

**www.Fennelly.com | 609.520.0061 | Fennelly@Fennelly.com**

**NAI Fennelly™**  
Commercial Real Estate Services, Worldwide.

The information contained herein has been given to us by the owner of the property or other sources we deem reliable. We have no reason to doubt its accuracy, but we do not guarantee it. All information should be verified prior to purchase or lease.

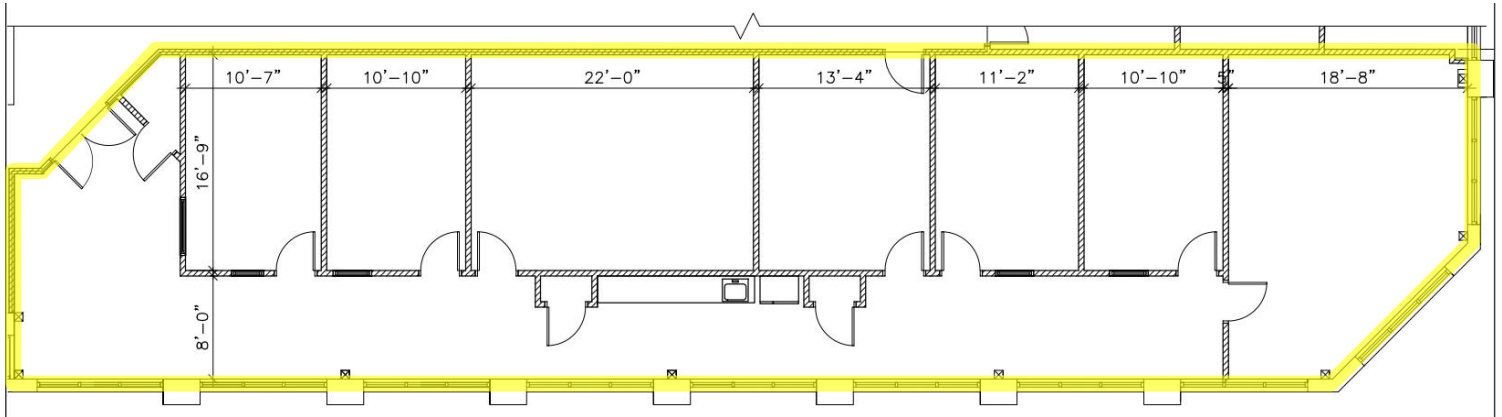

**Suite 101 - 3,623 SF**

**Building One - 1<sup>st</sup> Floor**

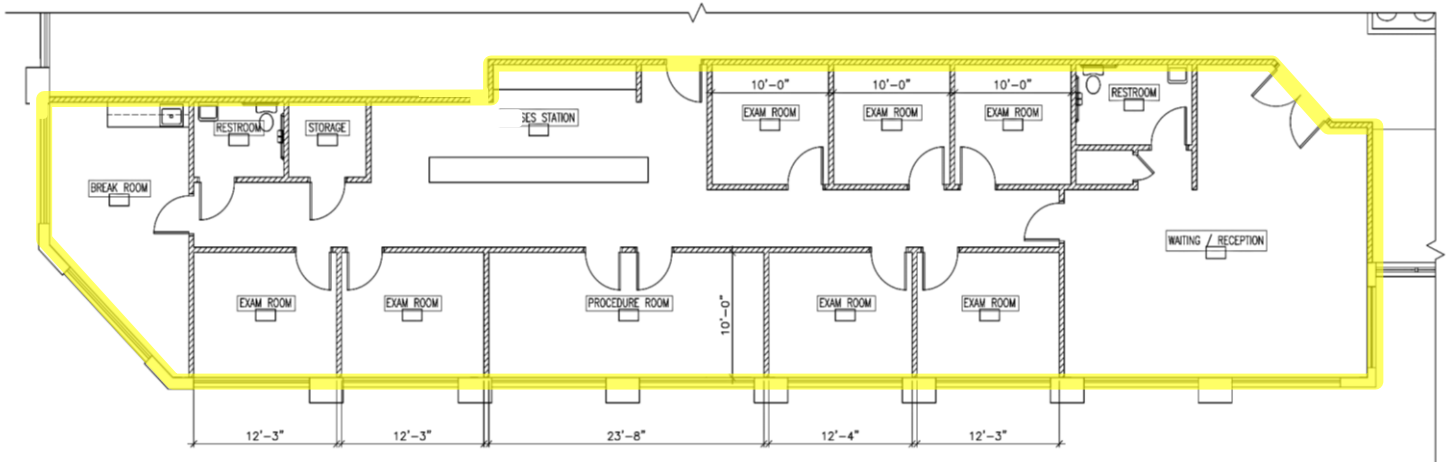

**Suite 206 - 3,711 SF**

**Building One - 2<sup>nd</sup> Floor**

**Contact: Jerry Fennelly, Patrick Dintrone**

[www.Fennelly.com](http://www.Fennelly.com) | 609.520.0061 | [Fennelly@Fennelly.com](mailto:Fennelly@Fennelly.com)

**NAI Fennelly™**  
Commercial Real Estate Services, Worldwide.

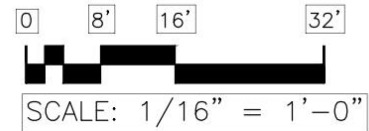
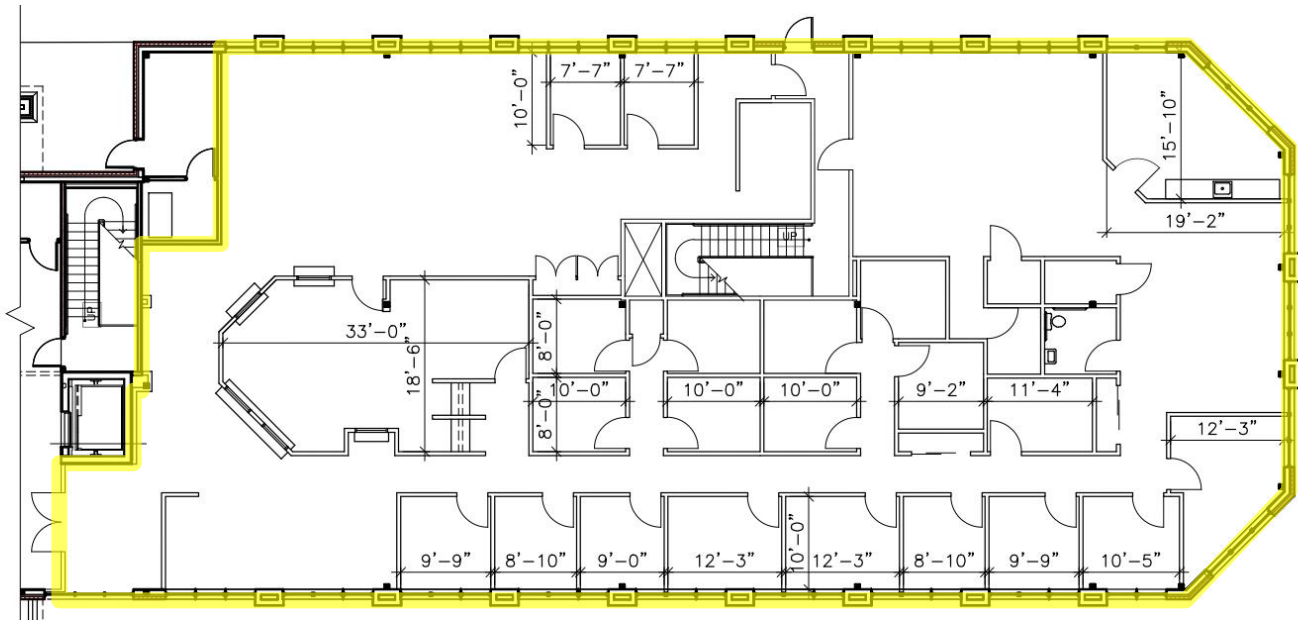

**Suite 100 – 8,228 SF**

**Building Two**

**Contact: Jerry Fennelly, Patrick Dintrone**

[www.Fennelly.com](http://www.Fennelly.com) | 609.520.0061 | [Fennelly@Fennelly.com](mailto:Fennelly@Fennelly.com)

**NAI Fennelly™**  
Commercial Real Estate Services, Worldwide.



# Van Nest Office Park | 3836-3840 Quakerbridge Road | Hamilton, NJ

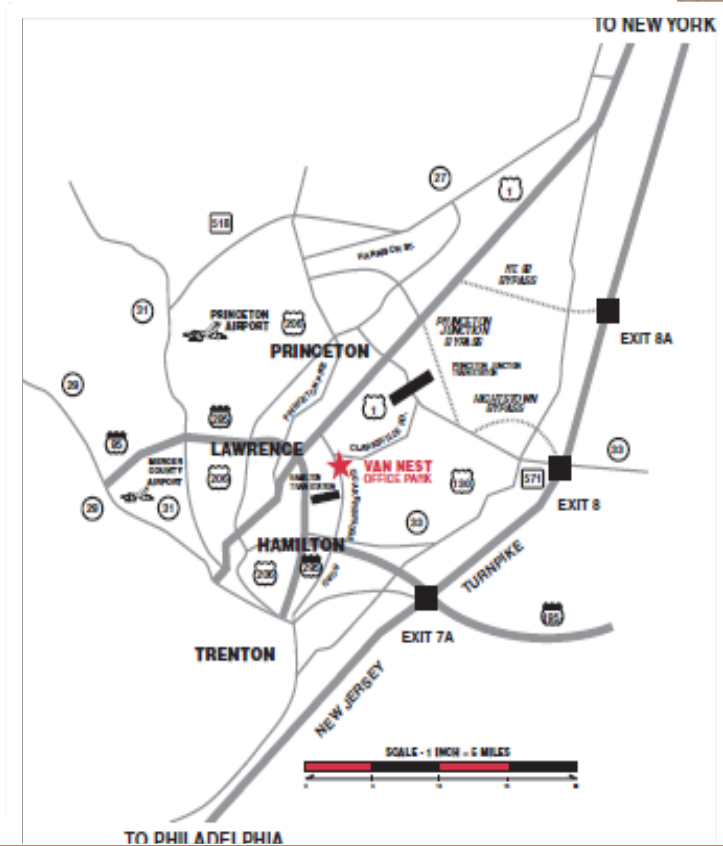

**Contact: Jerry Fennelly, Patrick Ditrone**

[www.Fennelly.com](http://www.Fennelly.com) | 609.520.0061 | [Fennelly@Fennelly.com](mailto:Fennelly@Fennelly.com)

**NAI Fennelly™**  
Commercial Real Estate Services, Worldwide.